

DIAP Tools, s.r.o.



Vnikací hroty



DIAP Tools, s.r.o., Přípotoční 835/31, 101 00 Praha
Tel: 212 244 254, 284 818 016, 284 812 040 / Fax: 284 814 040
diaptools@seznam.cz
www.diap.cz

Vnikací hroty

System: Rockwell, Vickers, Knoop

<p>HPD01C Geometrie: Rockwell</p>	<p>HPD08C Geometrie: Vickers</p>
<p>HPD02C Geometrie: Rockwell</p>	<p>HPD09C Geometrie: Vickers</p>
<p>HPD03C Geometrie: Rockwell</p>	<p>HPD10C Geometrie: Vickers</p>
<p>HPD04C Geometrie: Rockwell</p>	<p>HPD12C Geometrie: Vickers</p>
<p>HPD05C Geometrie: Vickers</p>	<p>HPD18C Geometrie: Vickers</p>
<p>HPD06C Geometrie: Vickers</p>	<p>HPD19C Geometrie: Vickers</p>
<p>HPD07C Geometrie: Vickers</p>	<p>HPD20C Geometrie: Rockwell</p>

Vnikací hroty

System: Rockwell, Vickers, Knoop

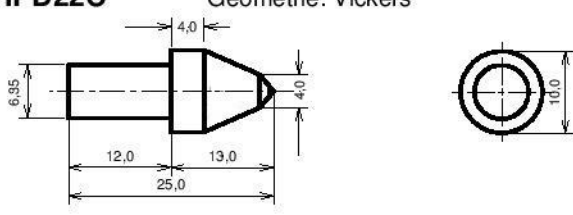
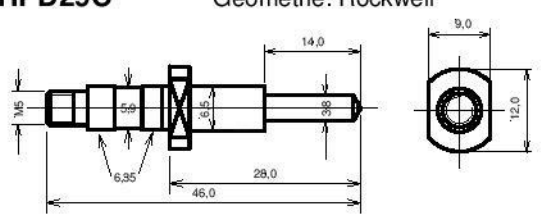
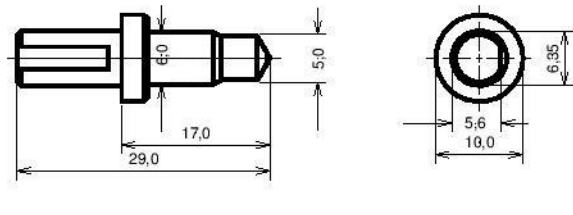
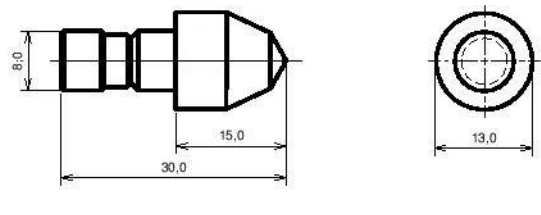
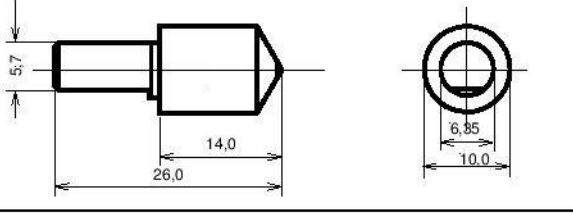
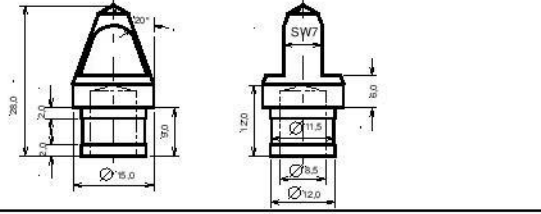
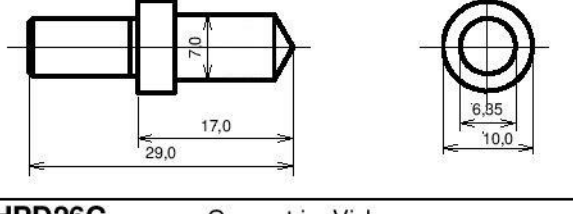
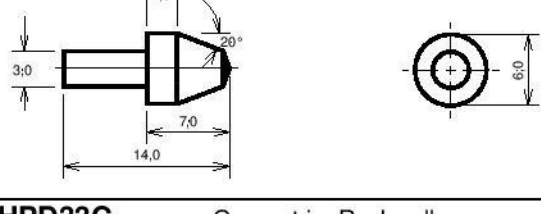
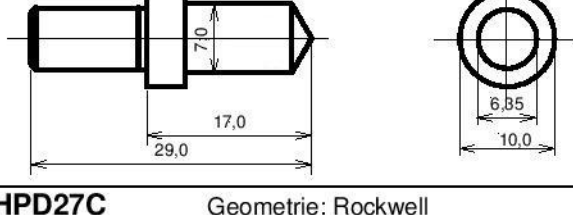
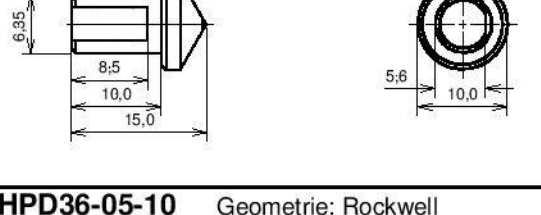
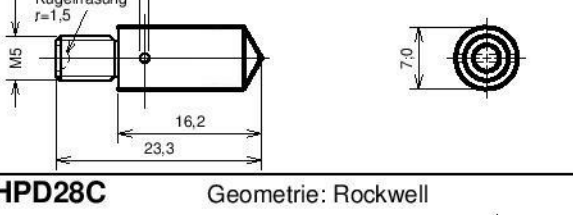
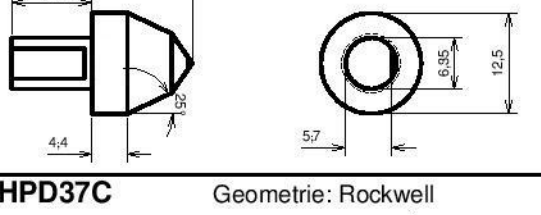
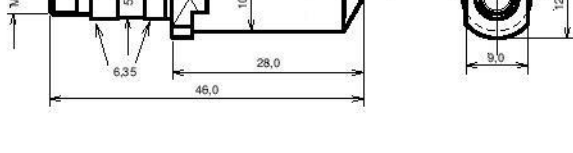
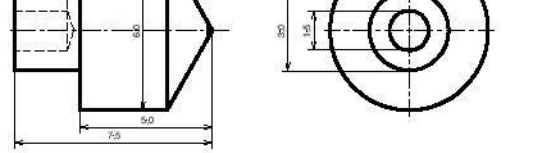
HPD22C Geometrie: Vickers 	HPD29C Geometrie: Rockwell 
HPD23C Geometrie: Vickers 	HPD30 Geometrie: Rockwell 
HPD24C Geometrie: Rockwell 	HPD31B Geometrie: Vickers 
HPD25C Geometrie: Rockwell 	HPD32C Geometrie: Vickers 
HPD26C Geometrie: Vickers 	HPD33C Geometrie: Rockwell 
HPD27C Geometrie: Rockwell 	HPD36-05-10 Geometrie: Rockwell 
HPD28C Geometrie: Rockwell 	HPD37C Geometrie: Rockwell 

Vnikací hroty

System: Rockwell, Vickers

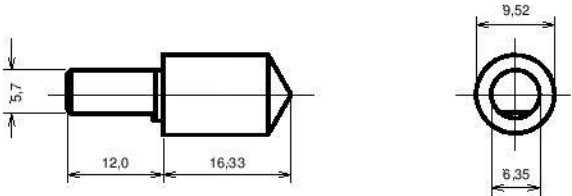
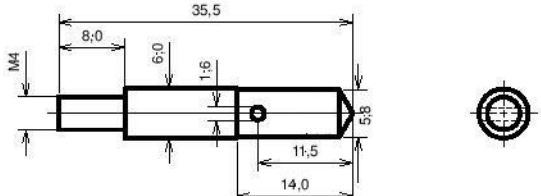
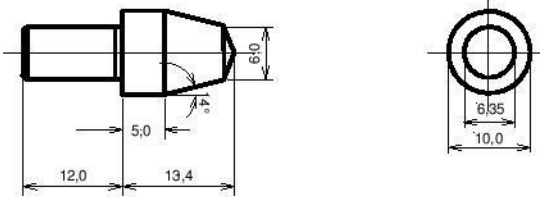
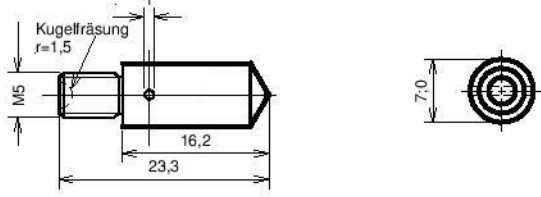
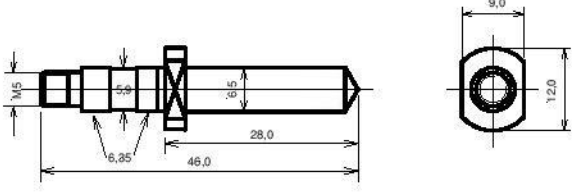
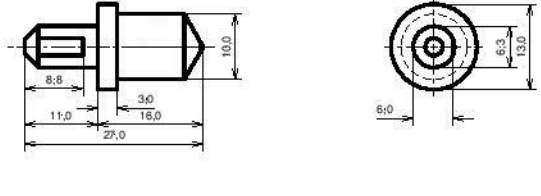
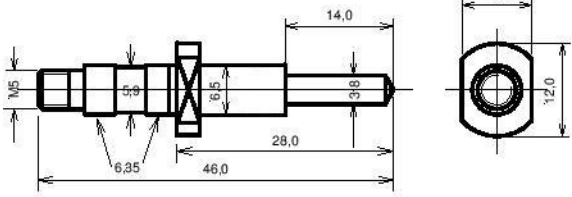
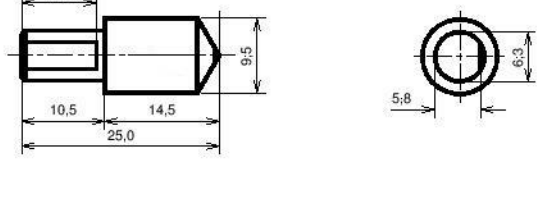
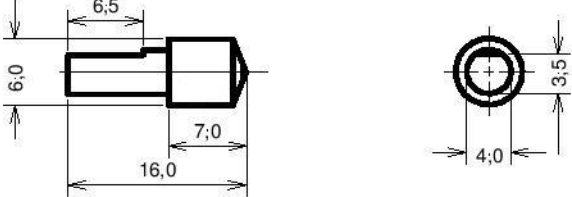
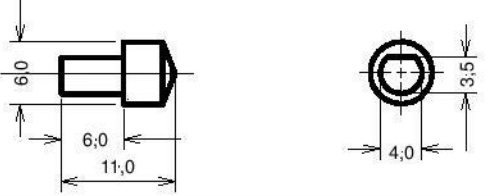
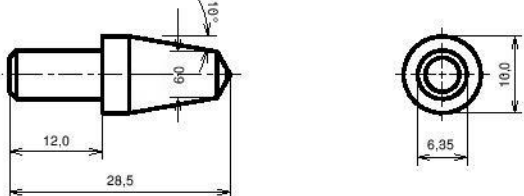
<p>HPD38C Geometrie: Rockwell</p> 	<p>HPD46C Geometrie: Rockwell</p> 
<p>HPD39C Geometrie: Vickers</p> 	<p>HPD47C Geometrie: Vickers</p> 
<p>HPD41C Geometrie: Vickers</p> 	<p>HPD48C Geometrie: Rockwell</p> 
<p>HPD42C Geometrie: Vickers</p> 	<p>HPD49C Geometrie: Rockwell</p> 
<p>HPD43C Geometrie: Vickers</p> 	
<p>HPD44C Geometrie: Vickers</p> 	
<p>HPD45C Geometrie: Vickers</p> 	



DIAP Tools, s.r.o.
Přípotoční 835/31
101 00 Praha 10 Vršovice
IČ: 27099491
DIČ: CZ27099491

Kontakt:

+420 284 818 016

+420 284 812 040

+420 212 244 254

diaptools@seznam.cz

www.diap.cz